

High Speed Dispersers Specifications and Dimensions

STANDARD FEATURES:

- 3 HP through 50 HP
- Driven by a totally enclosed fan cooled (TEFC), 230/460 V, 3 Ph, 50/60 Hz, inverter duty motor
- Mixing head hydraulically raised by an air/oil hydraulic lift
- High Speed Disperser blade
- Stainless steel type 304 wetted parts
- All non-stainless steel external surfaces coated with a white two-part coating
- Clamping device to secure mix vessel

AVAILABLE OPTIONS:

- Larger horsepower designs available
- Sanitary design with special polishes and custom enclosures
- Custom mix vessels designed and built to desired specifications
- Cover to seal mix chamber
- Tank mounted designs available
- Special motors including explosion proof, stainless steel, wash-down, and various voltages and frequencies
- Controls including variable frequency drives, explosion proof operator stations, and Human Machine Interfaces

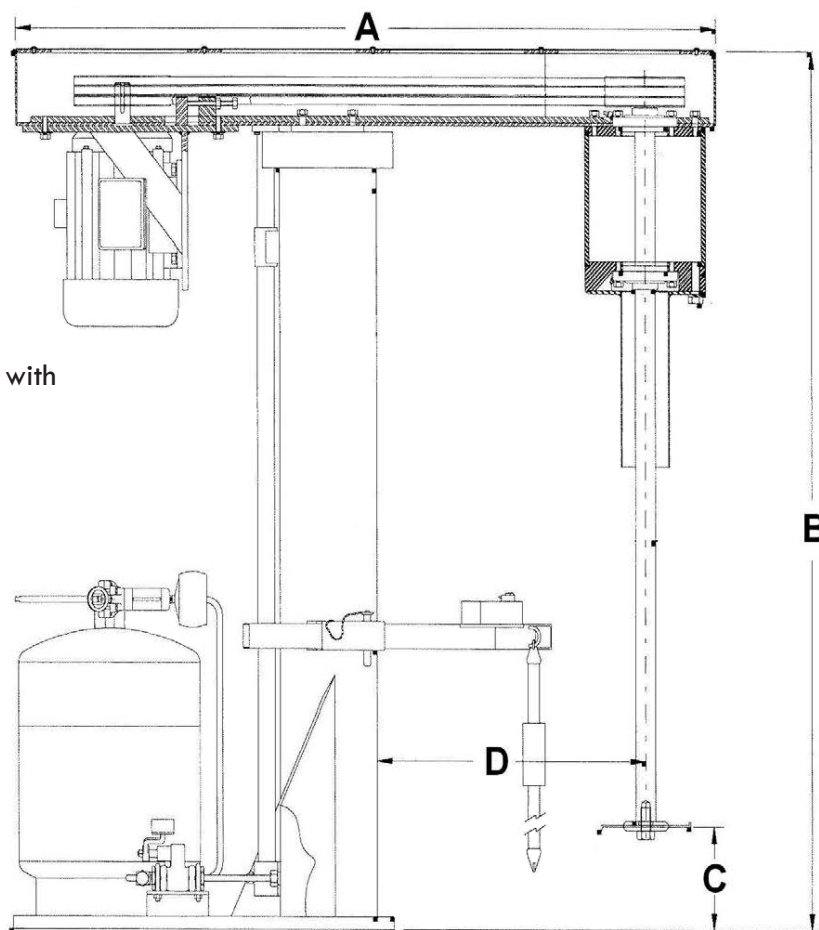

Model	HP	Shaft RPM	Blade Diameter		Overall Length (A)		Overall Width		Overall Lowered Height (B)		Lowered Blade Clearance (C)		Raised Blade Clearance		Lift Rise		Shaft to Lift Distance (D)	
			Inch	mm	Inch	mm	Inch	mm	Inch	mm	Inch	mm	Inch	mm	Inch	mm	Inch	mm
HSD-5	5	3,200	6	152	63	1,600	24	610	63	1,600	6	152	41	1,041	35	889	24	610
HSD-7.5	7.5	2,400	8	203	63	1,600	24	610	70	1,778	8	203	56	1,422	48	1,219	24	610
HSD-10	10	1,900	10	254	63	1,600	24	610	70	1,778	8	203	56	1,422	48	1,219	24	610
HSD-15	15	1,600	12	305	63	1,600	24	610	70	1,778	8	203	56	1,422	48	1,219	24	610
HSD-20	20	1,400	14	356	63	1,600	24	610	70	1,778	8	203	56	1,422	48	1,219	24	610
HSD-25	25	1,150	16	406	72	1,829	28	711	82	2,082	8	203	62	1,575	54	1,372	30	762
HSD-30	30	1,150	16	406	72	1,829	28	711	82	2,082	8	203	62	1,575	54	1,372	30	762
HSD-50	50	1,050	18	457	84	2,134	28	711	106	2,692	12	305	78	1,981	66	1,676	34	864

*Dimensions shown are approximate and subject to change without notice due to design improvements, selected options, or supplier component substitutions.



CHARLES ROSS & SON COMPANY

P.O. Box 12308
 710 Old Willets Path, Hauppauge, NY 11788
 631-234-0500 Fax: 631-234-0691
www.mixers.com
sales@mixers.com